

结构特点 Design features

- 内装、单端面、非平衡型、单弹簧并圈传动结构。
- 弹簧旋向根据轴运转方向确定：
 - 1、当从A方向看轴为顺时针旋向时，弹簧旋向为右旋，
 - 2、当从A方向看轴为逆时针旋向时，弹簧旋向为左旋。
- 安装尺寸符合JB/T 1472-1994标准
- Internally mounted, single face, unbalanced structure, single spring and driven by the abreast would rings on both ends of the spring, driven by brace ear and claw transmission.
- The spring rotating direction is determined by the direction of the shaft rotation:
 - 1、Clockwise rotation Looking the shaft from "A" side, the spring rotating direction is right-hand.
 - 2、Anticlockwise rotation looking the shaft from "A" side, the spring rotating direction is left-hand.
- Conform to the standard of JB/T1472-1994

材料 Materials(to DIN24960)

- 旋转环 Rotary Ring: U12、U22、Q22
- 静止环 Stationary Ring: B、U12、U22、Q2、Q22
- 辅助密封 Auxiliary Seal: P、E、V、T1
- 弹簧及其他结构件材料 Spring and Other Parts: F、G

适用范围 Operating limits

- 压力 Pressure: 0~0.8MPa
- 温度 Temperature: -20~200°C
- 线速度 Speeds: ≤ 13m/sec

用途 Applications

用于化工、石油化工、炼油、制冷、制药、造纸、给排水、污水处理等工业的泵类、反应釜、压缩机等类似的旋转轴密封。Used in all types of rotating equipment, pumps, mixers, agitators and compressors. to suit industries such as general chemical, oil refining, petrochemical, pharmaceutical, food processing, pulp and paper, and waste water treatment.

介质 Medium

油类、水、有机溶剂及其它弱腐蚀性溶液。
Oil, water, organic solvents and other weak corrosive fluid.

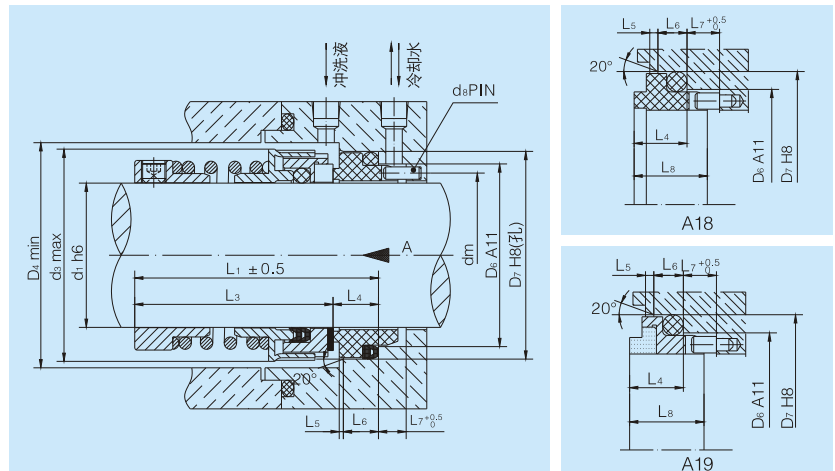

型号 Model	d1	d3	D4	D6	D7	dm	d8	L1	L3	L4	L5	L6	L7	L8
CN 103U-16	16	33	36	25	33	21	2	52	40	12	1.5	5.5	7	16
CN 103U-18	18	35	38	28	36	23	2	56	44	12	1.5	5.5	7	16
CN 103U-20	20	37	40	30	40	25	3	58	44	14	2.0	6.5	8	19
CN 103U-22	22	39	42	32	42	27	3	62	48	14	2.0	6.5	8	19
CN 103U-25	25	42	45	35	45	30	3	62	48	14	2.0	6.5	8	19
CN 103U-28	28	45	48	38	48	33	3	64	50	14	2.0	6.5	8	19
CN 103U-30	30	52	55	40	50	35	3	70	56	14	2.0	6.5	8	19
CN 103U-35	35	57	60	45	55	40	3	74	60	14	2.0	6.5	8	19
CN 103U-40	40	62	65	50	60	45	3	78	64	14	2.0	6.5	8	19
CN 103U-45	45	67	70	55	65	50	3	85	71	14	2.0	6.5	8	19
CN 103U-50	50	72	75	60	70	55	3	89	75	14	2.5	6.5	8	19
CN 103U-55	55	77	80	65	75	60	3	91	77	14	2.5	6.5	8	19
CN 103U-60	60	82	85	70	80	65	3	91	77	14	2.5	6.5	8	19
CN 103U-65	65	92	95	80	90	73	3	106	89	17	2.5	6.5	8	22
CN 103U-70	70	97	100	85	97	78	3	110	91	19	2.5	7.5	9	25
CN 103U-75	75	102	105	90	102	83	3	110	91	19	2.5	7.5	9	25
CN 103U-80	80	107	110	95	107	88	3	117	98	19	3.0	7.5	9	25
CN 103U-85	85	112	115	100	112	93	3	119	100	19	3.0	7.5	9	25
CN 103U-90	90	117	120	105	117	98	3	120	101	19	3.0	7.5	9	25
CN 103U-95	95	122	125	110	122	103	3	120	101	19	3.0	7.5	9	25
CN 103U-100	100	127	130	115	127	108	3	120	101	19	3.0	7.5	9	25
CN 103U-110	110	141	145	130	142	120	3	147	126	21	3.0	8.0	9	27
CN 103U-120	120	151	155	140	152	130	3	147	126	21	3.0	8.0	9	27